

CERTIFICATE

Certified Passive House Component

Component-ID 1885wi02 valid until 31st December 2026

Passive House Institute
Dr. Wolfgang Feist
64283 Darmstadt
Germany

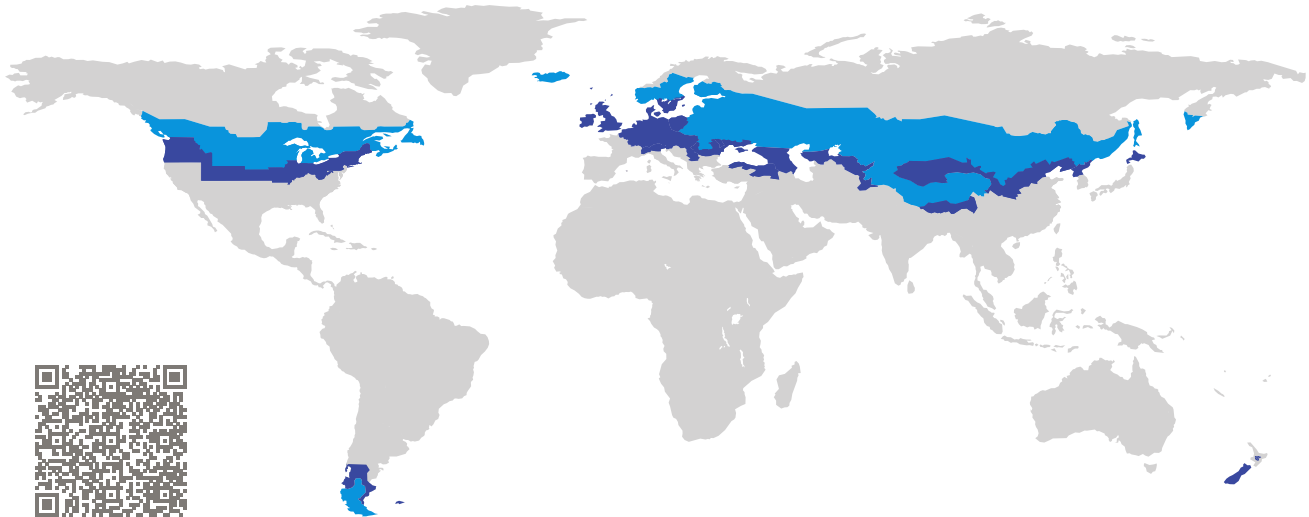

Category: **Window Frame**
Manufacturer: **pro Passivhausfenster GmbH,
Oberaudorf,
Germany**
Product name: **smartwin arctic**

**This certificate was awarded based on the following
criteria for the cold climate zone**

Comfort $U_W = 0.60 \leq 0.60 \text{ W}/(\text{m}^2 \text{ K})$
 $U_{W, \text{installed}} \leq 0.65 \text{ W}/(\text{m}^2 \text{ K})$
with $U_g = 0.52 \text{ W}/(\text{m}^2 \text{ K})$

Hygiene $f_{Rsi=0.25} \geq 0.75$

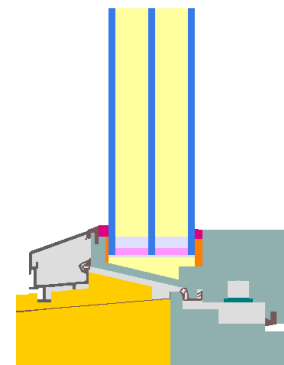

Passive House
efficiency class

phE

phD

phC

phB

phA

www.passivehouse.com

cold climate



**CERTIFIED
COMPONENT**

Passive House Institute

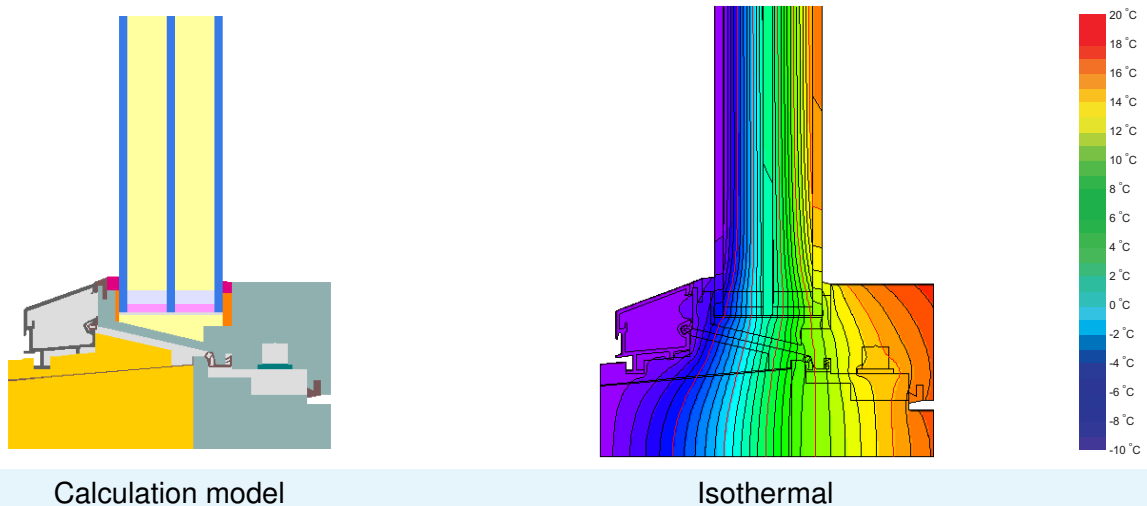

Description

Timber Aluminium frame, insulated by PET-foam with different densities, 0.036 and 0.055 W/(mK) and phenolic foam, 0.022 W/(mK) in the glazing rebate. Glass loads are carried by special corner pieces. The window installation will be designed individually by the manufacturer. Pane thickness: 48 mm (4/18/4/18/4), rebate depth: 13 mm. Spacer: Multitech G.

Explanation

The window U-values were calculated for the test window size of 1.23 m × 1.48 m with $U_g = 0.52$ W/(m² K). If a higher quality glazing is used, the window U-values will improve as follows:

Glazing	$U_g =$	0.52	0.60	0.48	0.35	W/(m ² K)
		↓	↓	↓	↓	
Window	$U_W =$	0.60	0.67	0.57	0.47	W/(m ² K)

Transparent building components are classified into efficiency classes depending on the heat losses through the opaque part. The frame U-Values, frame widths, thermal bridges at the glazing edge, and the glazing edge lengths are included in these heat losses. A more detailed report of the calculations performed in the context of certification is available from the manufacturer.

The Passive House Institute has defined international component criteria for seven climate zones. In principle, components which have been certified for climate zones with higher requirements may also be used in climates with less stringent requirements. In a particular climate zone it may make sense to use a component of a higher thermal quality which has been certified for a climate zone with more stringent requirements.

Further information relating to certification can be found on www.passivehouse.com and passipedia.org.

Frame values		Frame width b_f mm	U -value frame U_f W/(m ² K)	Ψ -glazing edge Ψ_g W/(m K)	Temp. Factor $f_{RSI=0.25}$ [-]
Flying Mullion (FM1)		92	0.61	0.027	0.76
Bottom (OB1)		77	0.62	0.028	0.75
Head (OH1)		77	0.54	0.028	0.76
Jamb (OJ1)		77	0.54	0.028	0.76
		Spacer: MULTITECH G		Secondary seal: Polysulfide	

Validated installations

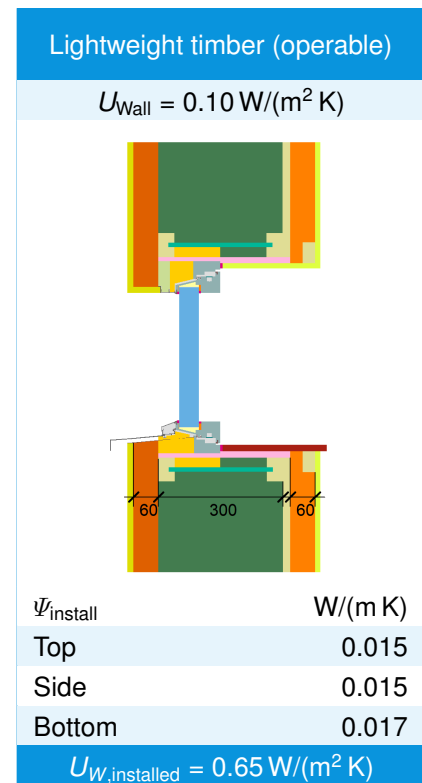
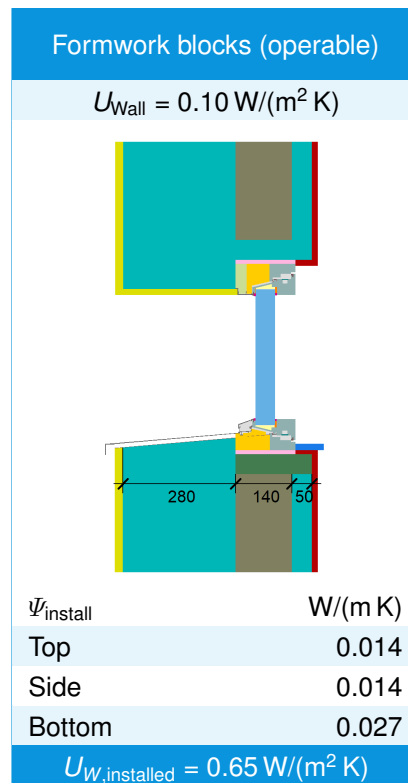
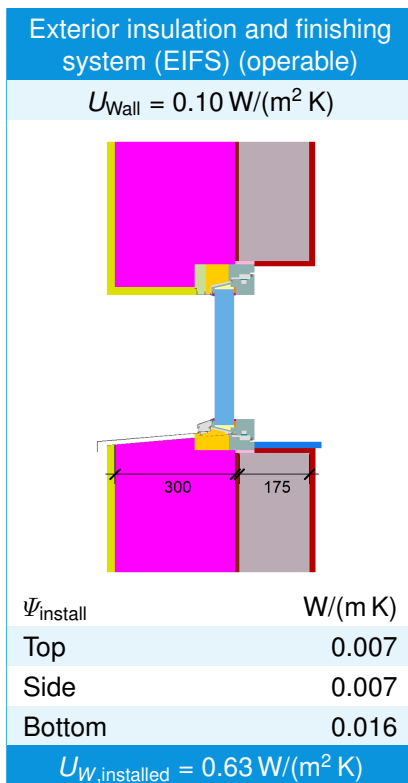

Disclaimer: The Passive House Institute GmbH (PHI) conducts heat-transfer analyses in accordance with the standards set out in Criteria and Algorithms for Certified Passive House Components: Transparent Building Components and Opening Elements in the Building Envelope, based on information provided by the manufacturer. PHI does not verify on-site implementation. It is the responsibility of the project leader to ensure that installed components match the certified specifications in terms of geometry, configuration, and materials. Manufacturers must make full product information available upon request to parties involved in a construction project. These parties may compare the provided information with project documentation and perform on-site inspections as part of the quality-assurance process.

